



PRODUCT FEATURES

- 3/4 HP Induction motor
- Belt driven permanently lubricated transmission
- Heat-treated hardened steel alloy gears and shafts
- Thermal overload protection
- Rigid cast iron body
- Three fixed speeds
- 25 litre stainless steel bowl
- Removable stainless steel bowl safety guard with built in ingredient chute
- Safety interlocked bowl guard and bowl lift Front mounted controls
- 15 minute analogue timer
- Non-slip rubber feet
- 1.8m cord with plug

STANDARD ACCESSORIES

- | | |
|-----------------------------------|---------------|
| • 25 litre bowl (stainless steel) | Ref # SP25-32 |
| • Beater (aluminum) | Ref # SP25-30 |
| • Whisk (stainless steel) | Ref # SP25-31 |
| • Dough hook (aluminum) | Ref # SP25-29 |

OPTIONAL ACCESSORIES

- | | |
|--------------------------------------|------------------|
| • 10L Reduction Kit with tools | Ref # ACC10/SP25 |
| • Reinforced Whisk (stainless steel) | Ref # 22031-A |

TECHNICAL DATA

Power	3/4 HP
Electrical data	240V / 50 / 1 Draw 6 Amps
	Single phase - plug supplied
Speed	3 speed - 108 / 183 / 352 rpm
Dimensions (LxWxH)	557 x 540 x 922 mm
Gross weight	110 kg
Reference	SP25-S

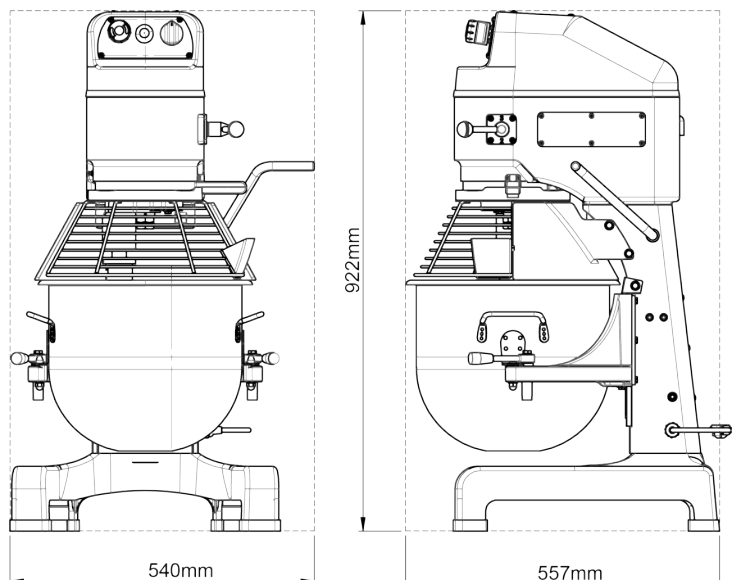
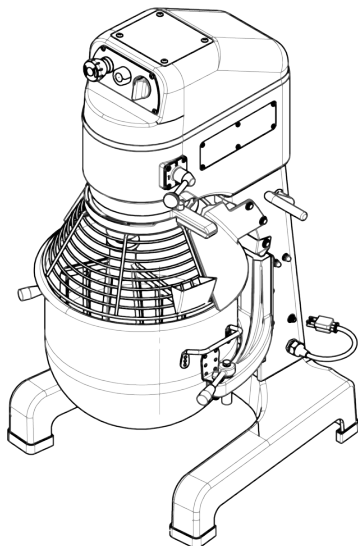

STANDARDS

