



PRODUCT FEATURES

- 3 HP Induction Motor
- Belt driven direct drive oil bath transmission
- Heat-treated hardened steel alloy gears and shafts
- Four fixed speeds
- Thermal overload protection
- Rigid cast iron body
- 80 litre stainless steel bowl
- Removable stainless steel bowl safety guard with built in ingredient chute
- Safety interlocked bowl guard and bowl lift
- Front mounted controls
- 15 minute analogue timer
- Non-slip rubber feet
- 1.8m cord no plug supplied

STANDARD ACCESSORIES

- | | | |
|-----------------------------------|-------|---------------|
| • 80 litre bowl (stainless steel) | Ref # | SPB80-A28 |
| • Beater (aluminum) | Ref # | SPB80-A26 |
| • Whisk (stainless steel) | Ref # | SPB80-A25 |
| • Dough hook (aluminum) | Ref # | SPB80-A27 |
| • Bowl trolley with handle | Ref # | Trolley/A80-N |

OPTIONAL ACCESSORIES

- | | |
|--------------------------------------|-------------------|
| • 40L Reduction kit with tools | Ref # ACC40/SPB80 |
| • Reinforced whisk (stainless steel) | Ref # A-8025-A |
| • Bowl scraper | Ref # SPB80/SCRP |

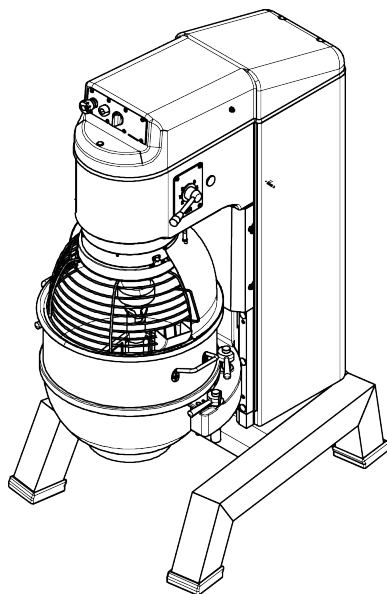

TECHNICAL DATA

Power	3 HP
Electrical data	415V/50/3 Draw 5 Amps
	Three Phase - no plug supplied
Speed	4 speed - 69 / 121 / 204 / 356 rpm
Dimensions (LxWxH)	1088 x 788 x 1559 mm
Gross weight	455 kg
Reference	SPB-80HI

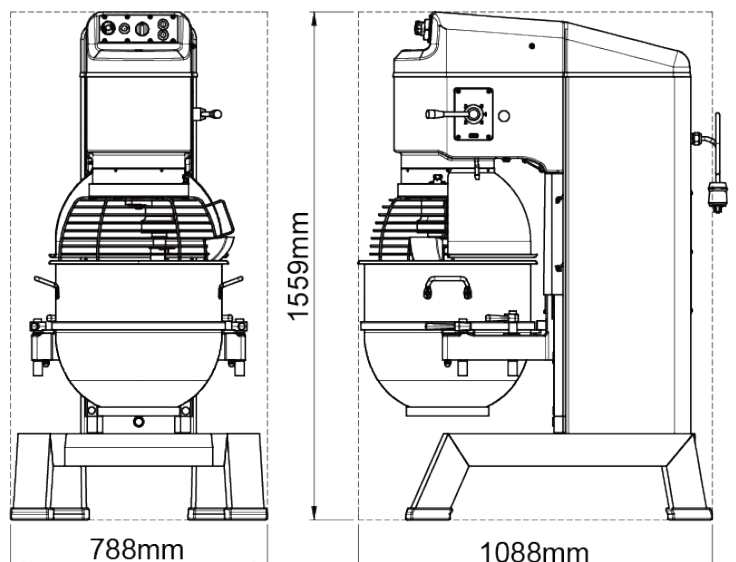

STANDARDS

